

REV	DESCRIPTION	DATE
B	ADDED NOTE: 1.	10/31/00

NOTE:

- ① 1. THE FOLLOWING STEEL DFLECTORS ARE
OPTIONALLY AVAILABLE:
- FOR USE WITH 246 TOOL; USE 123634-246.
- FOR USE WITH 2502/2503 TOOL USE 123634-2503.
- FOR USE WITH 2580 TOOL USE 123634-2580.

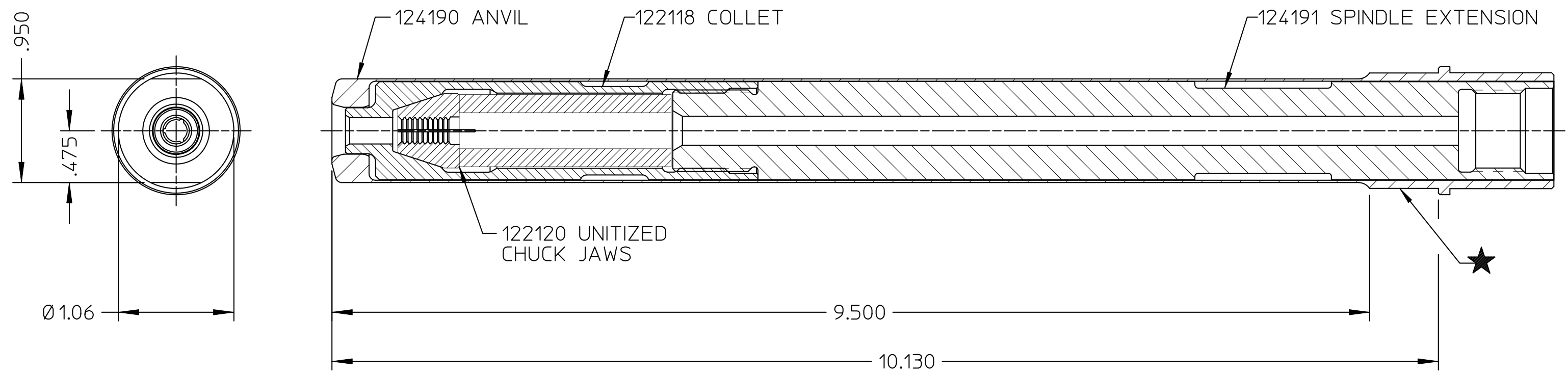

IDENTIFICATION PER SPEC 42-311: ★ ETCH			
HUCK INTERNATIONAL, INC., I.S.D. 1 CORPORATE DRIVE, P.O. BOX 2270 KINGSTON, NEW YORK 12401			
NOSE ASSEMBLY -10 BOM			
DET: SMR	CK: -	DATE: 05/26/94	SCALE: 2/1
FOC. FAC.	B	99-769-2	